



LabSOX™

AIR DISPERSION SOLUTIONS FOR
AIRFLOW SENSITIVE
CRITICAL ENVIRONMENTS

DUCTSOX®
Textile Air Dispersion Products



LabSox™ Products are Textile Air Dispersion Devices designed for laboratory environments (vivariums, pharmaceutical, research education, etc.) in critical applications commonly associated with a fume hood or other airflow sensitive equipment (scales, laser, microscope, etc). LabSox are also applicable to industrial or commercial kitchen applications.

Airflow in laboratories is a critical design factor as turbulent air can negatively affect research or even cause hood failure resulting in a compliance issue. The LabSox advantage is clear as air passes through specialized fabric panels resulting in uniform, low velocity, radially diverging air patterns with little, if any, turbulence.

LabSox products are not only ideal for labs of the future, but can be easily retrofitted to resolve air flow issues in existing facilities.

Applying Fabric

To be flexible for optimum design, LabSox solutions are available in a wide variety of products ranging from the D-Fuser style MetalPan or All-Fabric to traditional product configurations. With all of these options, the fabric is removable, simplifying installation and maintenance.



MetalPan™

Easily removed fabric face for Snap Frame or Clip Face options.

Sizes include:

- 24x24 ≤ 500 CFM
- 24x48 ≤ 1,000 CFM

All-Fabric™

Easily removed fabric face for Snap Frame or Clip Face options.

Sizes include:

- 24x24 ≤ 500 CFM
- 24x48 ≤ 1,000 CFM
- 24x96 ≤ 2,000 CFM

Half Round

For finished ceiling, larger dispersion panel for higher volume.

Airflow enters from top or end. Customized per application.

Quarter Round

For finished ceiling/wall location, larger dispersion panel for higher volume. Airflow enters from top, back or end. Customized per application.

Cylindrical

For open or high ceiling applications, system acts as duct and diffuser. Customized per application.

Fabric Options

Rx fabrics feature an antimicrobial treated, air permeable woven fabric. A complement of high permeable fabrics woven only with filament threads avoiding risk of shedding. All Rx fabrics are made with 50% post-industrial recycled content and include a durable anti-microbial treatment. The lightweight fabric can be easily cleaned and offers secondary filtration for make up air.



DT fabrics offer a silver color choice in a low maintenance, micro-perforated polyester fabric. DT is a stronger and more durable fabric choice for challenging (high wear) or industrial applications. Open outlets minimize filtering and extend periods between maintenance.

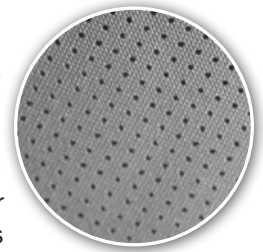

Better Air Dispersion

The following images reveal airflow patterns of two “fabric” faced D-Fusers and two industry standard “metal” faced diffusers. Each of the diffusers were tested at 750 CFM and yielded the airflow patterns as shown in both the end (24" width) and side (48" length) view.

Fabric: MetalPan D-Fuser

End View

Side View

Metal: Radial Flow Diffusers

End View

Side View

Fabric provides uniform, low velocity airflow patterns that have little or no turbulence. In many critical environments, this may enhance hood performance.

Metal diffusers use turbulent airflow to create radial airflow patterns that may reduce hood capture rates and possibly cause hood failure.

Air Flow Models

Surround Flow™

Surround Flow is the standard air flow model for all D-Fuser models. The radial shape of the fabric face produces a uniform and radially diverging air pattern. Even with high volumes, D-Fusers deliver less turbulence and lower noise than conventional metal D-Fusers.

Select Flow™

Select Flow combines customized vent patterns to include directional airflow control.

Reduced Noise

Fabric faced products offer noise levels at least 10NC quieter than metal.

The combination of perforated metal panels and louvers result in significantly higher noise criteria (NC) ratings than fabric faced D-Fuser products. The chart reveals NC levels for an industry standard metal diffuser and a D-Fuser at varying air volumes (500 CFM, 750 CFM, and 1000 CFM).

Traditional shaped products can be custom configured for quiet air delivery.

Noise Criteria Comparison Common Metal vs. D-Fuser

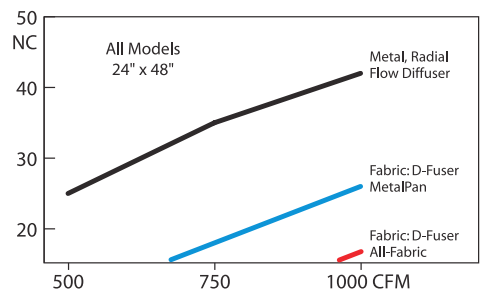

D-Fuser™ MetalPan™

The MetalPan LabSox combines the traditional metal backpan with the unique advantages of a fabric face for improved airflow performance using an industry standard installation method. The construction features a metal backpan with snap frame and fabric face. The shallow 6-inch depth of the face provides a low profile dispersion panel, yet delivers excellent performance.



24" x 24" MetalPan D-Fuser, Snap Frame



24" x 48" MetalPan D-Fuser, Snap Frame



Snap Frame released and face removed, reveals rigid diffusion panel

Features:

- Industry standard configuration
- Simple, snap frame installation
- Interchangeable fabric face
- Our standard backpan contains over 55% recycled content
- Lightweight (10 lbs lighter than metal for 24" x 48")
- Shallow 6" face depth and tapered ends
- Capable of airflow volumes up to 1,000 CFM (24" x 48")

Options:

- Size 24" x 24", 24" x 48"
- Optional Select Flow
- Inlet diameter
- Filtration
- Insulated backpan
- Backpan construction (steel, aluminum, or stainless steel)

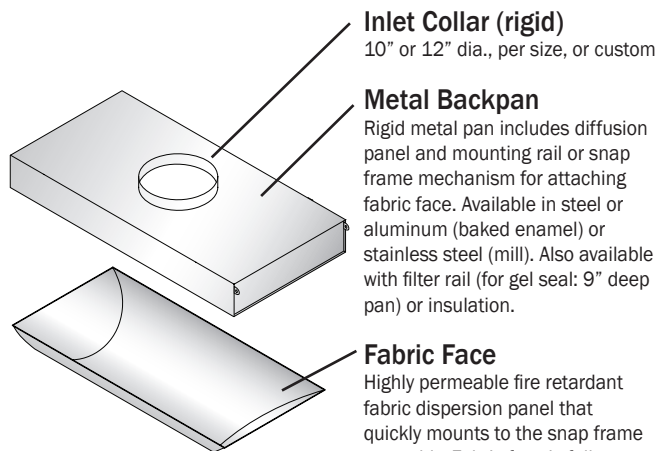

Inlet Collar (rigid)

10" or 12" dia., per size, or custom

Metal Backpan

Rigid metal pan includes diffusion panel and mounting rail or snap frame mechanism for attaching fabric face. Available in steel or aluminum (baked enamel) or stainless steel (mill). Also available with filter rail (for gel seal: 9" deep pan) or insulation.

Fabric Face

Highly permeable fire retardant fabric dispersion panel that quickly mounts to the snap frame assembly. Fabric face is fully launderable and available in either Surround Flow (standard) or Select Flow dispersion options. The fabric face construction varies by attachment type.

MetalPan™ D-Fuser

Metal Backpan Offers Short 6" Face Depth and Easy Installation

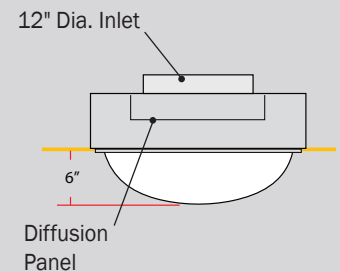

*Patent Pending

Clip Face Option

Developed as a budget-friendly alternative, the Clip Face allows the fabric face to affix directly to the metal backpan. While providing the same premium air dispersion characteristics, sewn-in clips on the fabric face easily attach to the mounting rail on the backpan. This simpler design eliminates the snap frame.

The standard model is steel with a baked enamel finish. Other options include coated aluminum or stainless steel.

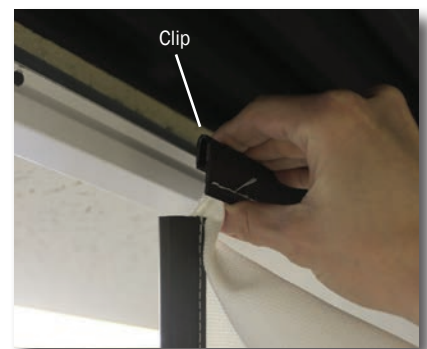
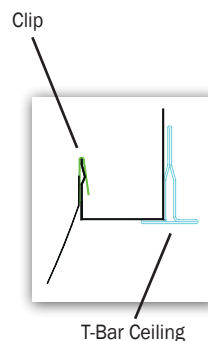

D-Fuser™ All-Fabric™

The All-Fabric LabSox product features an innovative snap frame aluminum extrusion which secures the fabric assembly in place and allows it to be easily removed for maintenance. With this product, the only ceiling penetration required is for the inlet connection. The slightly larger and deeper 9-inch face profile of the All-Fabric model increases internal mixing volume and decreases average discharge velocity.



24" x 48" All-Fabric D-Fuser, Snap Frame

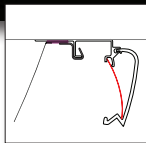

Snap Frame (open)

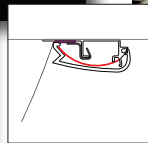

Snap Frame (closed)



24" x 96" All-Fabric D-Fuser, Snap Frame

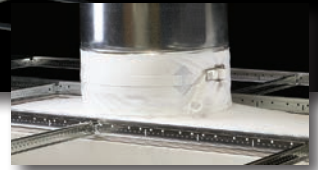

Fabric Inlet Connection

All-Fabric™ D-Fuser

35% More Surface Area Yields Lower Average Discharge Velocities

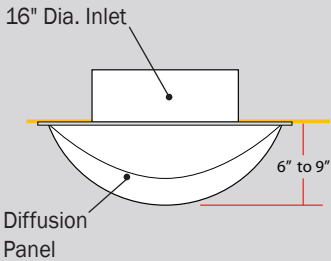

Fabric Inlet Collar

16" dia. standard, zips to fabric assembly, seals to rigid supply duct.

Snap Frame

Aluminum frame secures fabric assembly to T-bar on finished ceiling. Hook and loop fastener eases alignment.

Fabric Assembly

Includes a non-porous fabric backpanel, a flexible diffusion panel, and a fabric face. Added depth and size increases dispersion area, improving airflow and discharge velocity.

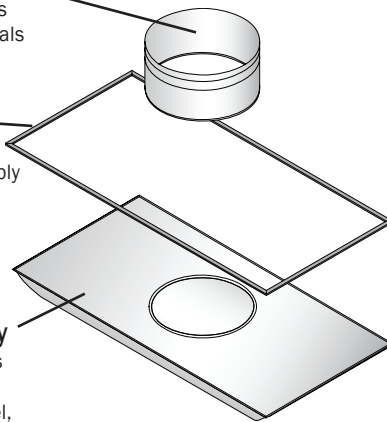

*Patent Pending

Features:

- Lower discharge velocity
- Simple, snap frame installation
- Universal installation configurations (T-bar or finished ceiling)
- Lightweight shipping
- Increased airflow volume per unit
- Easy maintenance
- Quiet

Options:

- Standard 24" x 24", 24" x 48", 24" x 96" (custom sizes available)
- Surround Flow (std.) or Select Flow
- Custom inlet size and position

Retrofit Option

To address airflow issues in existing facilities, retrofit options are available to mount to existing diffusers or directly to existing ductwork.

Besides airflow, these units can also be used to minimize airborne particles emitted from aging systems with lined ductwork.





DuctSox products have been accepted within key industry organizations such as ASHRAE, Underwriters Laboratories (US & Canada), International Code Council, and by many building code authorities throughout the world.

More than evolving our standard products, DuctSox strives to be the leader in the industry through our commitment to quality, service, and innovation.

To better support our Global Distribution Network, we have expanded our production capabilities to Kunshan, China and Guadalajara, Mexico.

DUCTSOX[®]

Textile Air Dispersion Products

9866 Kapp Court, Peosta, IA 52068
Ph: 563-588-5300 • Toll Free: 866-382-8769 • Fax: 563-588-5330

www.ductsox.com



LabSox products are constructed of Rx or DT fabrics which are classified by Underwriters Laboratories as an air distribution device in accordance with the requirements of NFPA 90A. Rx25 and Rx50 are also classified in accordance with ICC Evaluation Service AC167 and UL2518.

Products may be covered by one or more of the following patents: 6565430, 6558250, 5769708, 6425417, 6626754, 6280320, 6960130, 6958011, 6953396, 8434526, 8676545, 8808075, and 8844578. Other patents pending.

A Subsidiary of Rite-Hite Holding Corporation

DSL5B0315A
© 2015 DuctSox Corp.